

# 4SHP16LS

## PRODUCT SPECIFICATIONS

## 16 SEER SPLIT ENHANCED HEAT PUMP

FORM NO. 4SHP16LS-100 (05/2014)



### COMFORT SYNC COMMUNICATING THERMOSTAT ENABLED

#### COMPRESSOR

- High-efficiency 2 stage Copeland Ultra Tech™ scroll compressor
- R410a refrigerant
- Grommet mounted compressor for quiet operation
- Internally protected against high temperature motor overload conditions
- Heavy-duty compressor sound blanket for quiet operation

#### CABINET

- Full metal louvered panel coil guard protection
- Controls located in corner post for easy installation and service
- Rounded corners for safety and attractive, clean appearance
- Baked polyester paint finish over galvanized steel for maximum durability
- PVC coated wire fan discharge grill
- External gauge ports for easy service
- Raised base pan with ports allows for excellent water and debris drainage

#### COIL

- Enhanced aluminum fins and copper tubing for high efficiency and capacity
- Raised coil prevents debris from collecting in bottom of coil and causing loss of airflow

#### COMPONENTS

- Full metal louvered panels remove for easy coil cleaning and service
- Bi-directional filter drier for long-lasting durability and system protection
- Discharge muffler for quiet operation
- Factory installed crank case heater
- Factory installed high and low pressure switch
- Advanced design defrost system featuring a smart logic for power consumption savings
- Service valves positioned for quick installation and easy service
- Trade available components
- Quiet Shift™ capable for sound control during defrost
- Communicating features
- Thermostat flexibility: works with the Comfort Sync T-Stat (when matched with communicating indoor unit) or a conventional 24V T-Stat
- Self diagnostics saves last 10 fault codes regardless of power interruption

#### DESIGN

- Designed for ambients up to 125°F

#### WARRANTY

10 year limited warranty on compressor, 10 year limited warranty on all parts, extended warranty available\*

*\*Warranty provides for a total of 10 years of limited warranty coverage (Standard 5-year limited parts warranty plus an additional 5-year limited extended parts warranty). Warranty must be registered online within 60 days of installation to qualify for 10-year coverage. Unregistered equipment default to 5-year coverage. Lifetime limited heat exchanger warranty applies to registered equipment only (Standard 20 years with no online registration See full warranty at [www.alliedair.com](http://www.alliedair.com) for terms, conditions and exclusions.*



**MODEL NUMBER GUIDE**

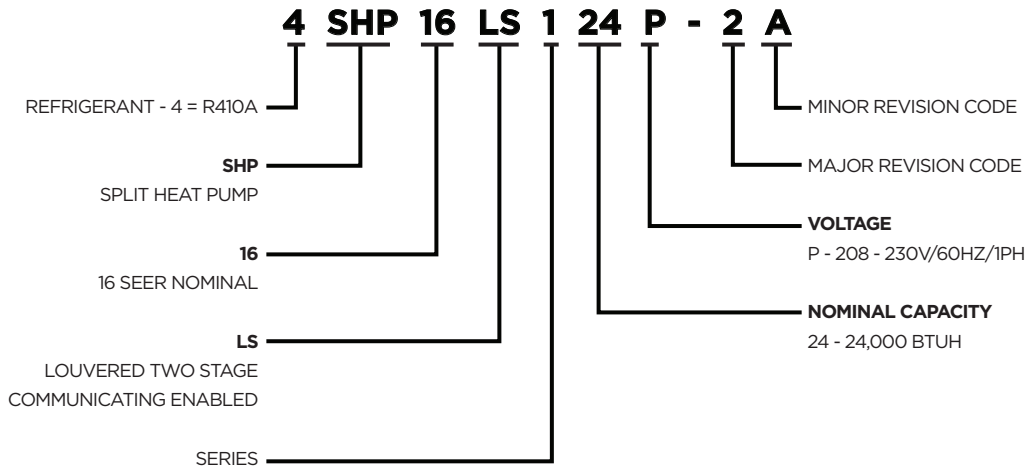

**PHYSICAL AND ELECTRICAL**

Model	Voltage/Hz/Phase	Voltage Range	Min. Circuit Amp.	Max. Over current Device (amps)	Compressor		Fan Motor			Refrig. Charge (oz.)	Weight (lbs.)
					Rated Load (amps)	Locked Rotor (amps)	Rated Load (amps)	Rated HP	Nom. RPM		
4SHP16LS124P-2	208-230-60/1	197-253	13.5	20	11.4	52	0.7	1/10	1075	146	207
4SHP16LS136P-2	208-230-60/1	197-253	22.5	35	19.0	82	1.7	1/4	825	192	253
4SHP16LS148P-2	208-230-60/1	197-253	28.2	45	24.0	96	1.8	1/3	825	236	288
4SHP16LS160P-2	208-230-60/1	197-253	35.1	60	26.0	118	2.8	1/3	ECM	244	313

**UNIT DIMENSIONS (IN.) AND SOUND RATINGS**

Model No.	Dimensions			Sound Rating dBA
	A	B	C	
4SHP16LS124P-2	24-3/4	26-3/4	33-3/4	73
4SHP16LS136P-2	29-3/8	31-1/4	37-3/4	75
4SHP16LS148P-2	35-3/4	37-3/4	37-3/4	75
4SHP16LS160P-2	35-3/4	37-3/4	43-3/4	74

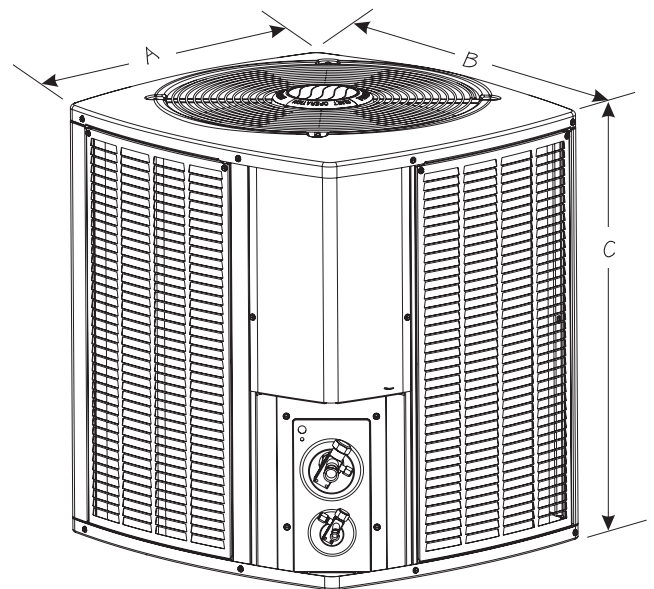

**COOLING PERFORMANCE WITH AIR HANDLERS AND FURNACES**

Outdoor Model	Indoor Model		Cooling				Heating				CFM	Refrigerant Connection				Refrig. Line Size		Indoor Expansion Device		
	Evaporator Coil or Air Handler <sup>2</sup>	Furnaces	SEER	EER	ARI Rated Capacity	Rated Sensible Capacity	HSPF	47		17		Outdoor		Indoor		Suction	Liquid	Piston <sup>2</sup>	TXV	
								Btuh	COP	Btuh		COP	Suction	Liquid	Suction					Liquid
<b>4SHP16LS124P-2</b>	BCS2M24@00NA1P		15.0	12.0	24,000	17,400	8.5	24,000	3.3	14,000	2.40	850	3/4	3/8	3/4	3/8	3/4	3/8		
	E(U,C,M,H)1P36B	EFV08BC	14.5	12.0	24,000	17,400	8.5	24,000	3.3	14,000	2.40	850	3/4	3/8	3/4	3/8	3/4	3/8		
	E(U,M,H)1P29B	EFV08BC	14.5	11.5	24,000	17,400	8.5	24,000	3.3	14,000	2.40	850	3/4	3/8	3/4	3/8	3/4	3/8		
	E(U,C,M,H)1P29A	A80DF1E045A12	14.0	12.0	24,000	17,400	8.5	22,600	3.3	14,000	2.40	850	3/4	3/8	3/4	3/8	3/4	3/8		
	E(U,C,M,H)1P36A	A80DF1E045A12	14.5	12.0	24,000	17,400	8.5	22,000	3.3	14,000	2.40	850	3/4	3/8	3/4	3/8	3/4	3/8		
	E(U,C,M,H)1P29B	A80DF1E070B12	13.5	11.5	24,000	17,400	8.5	22,600	3.3	14,000	2.40	850	3/4	3/8	3/4	3/8	3/4	3/8		
	E(U,C,M,H)1P36B	A80DF1E070B12	14.0	11.5	24,000	17,400	8.5	22,000	3.3	14,000	2.40	850	3/4	3/8	3/4	3/8	3/4	3/8		
	E(U,C,M,H)1P29A	A80+2V070A12	14.5	12.0	24,000	17,400	8.5	22,600	3.3	14,000	2.40	850	3/4	3/8	3/4	3/8	3/4	3/8		
	E(U,C,M,H)1P36A	A80+2V070A12	14.5	12.0	24,000	17,400	8.5	22,000	3.3	14,000	2.40	850	3/4	3/8	3/4	3/8	3/4	3/8		
	E(U,C,M,H)1P29B	A80+2V090B16	14.5	12.0	24,000	17,400	8.5	22,600	3.3	14,000	2.40	850	3/4	3/8	3/4	3/8	3/4	3/8		
	E(U,C,M,H)1P36B	A80+2V090B16	14.5	12.0	24,000	17,400	8.5	22,000	3.3	14,000	2.40	850	3/4	3/8	3/4	3/8	3/4	3/8		
	E(U,M,H)1P29B	A80+2V090B16	14.5	12.0	24,000	17,400	8.5	22,600	3.3	14,000	2.40	850	3/4	3/8	3/4	3/8	3/4	3/8		
	E(U,C,M,H)1P29A	A80UH1E045A12*	14.5	12.0	24,000	17,400	8.5	22,600	3.3	14,000	2.40	850	3/4	3/8	3/4	3/8	3/4	3/8		
	E(U,C,M,H)1P36A	A80UH1E045A12*	14.5	12.0	24,000	17,400	8.5	22,000	3.3	14,000	2.40	850	3/4	3/8	3/4	3/8	3/4	3/8		
	E(U,C,M,H)1P29B	A80UH1E070B12*	13.5	11.5	24,000	17,400	8.5	22,600	3.3	14,000	2.40	850	3/4	3/8	3/4	3/8	3/4	3/8		
	E(U,C,M,H)1P36B	A80UH1E070B12*	14.0	11.5	24,000	17,400	8.5	22,000	3.3	14,000	2.40	850	3/4	3/8	3/4	3/8	3/4	3/8		
	E(U,C,M,H)1P36B	A80#2V090B12	15.0	12.5	24,000	17,400	8.5	22,000	3.3	14,000	2.40	850	3/4	3/8	3/4	3/8	3/4	3/8		
	E(U,M,H)1P29B	A80#2V090B12	14.5	12.5	24,000	17,400	8.5	22,600	3.3	14,000	2.40	850	3/4	3/8	3/4	3/8	3/4	3/8		
	E(U,C,M,H)1P36B	A80#2V090B16	14.5	12.0	24,000	17,400	8.5	22,000	3.3	14,000	2.40	850	3/4	3/8	3/4	3/8	3/4	3/8		
	E(U,M,H)1P29B	A80#2V090B16	14.5	12.0	24,000	17,400	8.5	22,600	3.3	14,000	2.40	850	3/4	3/8	3/4	3/8	3/4	3/8		
	E(U,C,M,H)1P29B	A95DF2V045B12S	14.5	12.0	24,000	17,400	8.5	22,600	3.3	14,000	2.40	850	3/4	3/8	3/4	3/8	3/4	3/8		
	E(U,C,M,H)1P36B	A95DF2V045B12S	14.5	12.0	24,000	17,400	8.5	22,000	3.3	14,000	2.40	850	3/4	3/8	3/4	3/8	3/4	3/8		
	E(U,C,M,H)1P29B	A95UH1E070B12S	13.5	12.0	24,000	17,400	8.5	22,600	3.3	14,000	2.40	850	3/4	3/8	3/4	3/8	3/4	3/8		
	E(U,C,M,H)1P36B	A95UH1E070B12S	14.0	12.0	24,000	17,400	8.5	22,000	3.3	14,000	2.40	850	3/4	3/8	3/4	3/8	3/4	3/8		
	E(U,C,M,H)1P29B	A95#2V045B12S	14.5	12.0	24,000	17,400	8.5	22,600	3.3	14,000	2.40	850	3/4	3/8	3/4	3/8	3/4	3/8		
	E(U,C,M,H)1P36B	A95#2V045B12S	15.0	12.0	24,000	17,400	8.5	22,000	3.3	14,000	2.40	850	3/4	3/8	3/4	3/8	3/4	3/8		
	E(U,C,M,H)1P29B	A95#2V070B12S	15.0	12.5	24,000	17,400	8.5	22,600	3.3	14,000	2.40	850	3/4	3/8	3/4	3/8	3/4	3/8		
	E(U,C,M,H)1P36B	A95#2V070B12S	15.0	12.5	24,000	17,400	8.5	22,000	3.3	14,000	2.40	850	3/4	3/8	3/4	3/8	3/4	3/8		
	E(U,C,M,H)1P36C	A95#2V090C12S	15.0	12.5	24,000	17,400	8.5	22,000	3.3	14,000	2.40	850	3/4	3/8	3/4	3/8	3/4	3/8		
	E(U,C,M,H)1P36B	A96DFMV070B12 A97DSMV070B12	14.5	12.0	24,000	17,400	8.5	22,000	3.3	14,000	2.40	850	3/4	3/8	3/4	3/8	3/4	3/8		

NA  
H4TXV01

+ DF or DS      Note:  
 # UH or US      1 Certified in accordance with Unitary Air Conditioner Certification Program, which is based on AHRI Standard 210/240.  
 @ V or S      2 Required to achieve AHRI rating. If NA (Not Applicable) is in the piston column, then TXV is required  
 3 A blower time delay is required to achieve AHRI rating. This feature is standard on all Allied Air Enterprises furnace and air handler products.

**COOLING PERFORMANCE WITH AIR HANDLERS AND FURNACES**

Outdoor Model	Indoor Model		Cooling				Heating				CFM	Refrigerant Connection				Refrig. Line Size		Indoor Expansion Device		
	Evaporator Coil or Air Handler <sup>2</sup>	Furnaces	SEER	EER	ARI Rated Capacity	Rated Sensible Capacity	HSPF	47		17		Outdoor		Indoor		Suction	Liquid	Piston <sup>2</sup>	TXV	
								Btuh	COP	Btuh		COP	Suction	Liquid	Suction					Liquid
<b>4SHP16LS124P-2</b>	E(U,M,H)1P29B	A96DFMV070B12	14.5	12.0	24,000	17,400	8.5	22,600	3.3	14,000	2.40	850	3/4	3/8	3/4	3/8	3/4	3/8	NA	H4TXV01
	E(U,C,M,H)1P36B	A97DSMV070B12	14.5	12.0	24,000	17,400	8.5	22,000	3.3	14,000	2.40	850	3/4	3/8	3/4	3/8	3/4	3/8		
	E(U,M,H)1P29B	A96UHMV070B12	14.5	12.0	24,000	17,400	8.5	22,600	3.3	14,000	2.40	850	3/4	3/8	3/4	3/8	3/4	3/8		
	E(U,C,M,H)1P36C	A97USMV070B12	14.5	12.0	24,000	17,400	8.5	22,000	3.3	14,000	2.40	850	3/4	3/8	3/4	3/8	3/4	3/8		
	E(U,C,M,H)1P36B	A96UHMV090C12	15.0	12.0	24,000	17,400	8.5	24,000	3.3	14,000	2.40	850	3/4	3/8	3/4	3/8	3/4	3/8		
	E(U,M,H)1P29B	A97USMV090C12	15.0	12.0	24,000	17,400	8.5	24,000	3.3	14,000	2.40	850	3/4	3/8	3/4	3/8	3/4	3/8		
	E(U,C,M,H)1P36B	LBR,LUF*****V14	14.5	12.0	24,000	17,400	8.5	24,000	3.3	14,000	2.40	850	3/4	3/8	3/4	3/8	3/4	3/8		
	E(U,M,H)1P29B	LBR,LUF*****V14	14.5	12.0	24,000	17,400	8.5	24,000	3.3	14,000	2.40	850	3/4	3/8	3/4	3/8	3/4	3/8		
<b>4SHP16LS136P-2</b>	BCS2M36@OONA1P		15.0	12.0	35,000	25,400	8.5	35,000	3.3	22,000	2.40	1,310	7/8	3/8	7/8	3/8	7/8	3/8	NA	H4TXV01
	E(U,C,M,H)1P36B	EFV12BC	15.0	12.5	35,000	25,400	8.5	34,600	3.3	22,000	2.40	1,310	7/8	3/8	3/4	3/8	7/8	3/8		
	E(U,C,M,H)1P43B	EFV12BC	15.0	12.5	35,000	25,400	8.5	34,600	3.3	22,000	2.40	1,310	7/8	3/8	7/8	3/8	7/8	3/8		
	E(U,C,M,H)1P36B	A80DFIE090B16	14.5	11.5	35,000	25,400	8.5	34,600	3.3	22,000	2.40	1,310	7/8	3/8	3/4	3/8	7/8	3/8		
	E(U,C,M,H)1P43B	A80DFIE090B16	14.5	12.0	35,000	25,400	8.5	34,600	3.3	22,000	2.40	1,310	7/8	3/8	7/8	3/8	7/8	3/8		
	E(U,C,M,H)1P36B	A80+2V090B16	15.0	12.5	35,000	25,400	8.5	34,600	3.3	22,000	2.40	1,310	7/8	3/8	3/4	3/8	7/8	3/8		
	E(U,C,M,H)1P36C	A80+2V110C20	15.0	12.5	35,000	25,400	8.5	34,600	3.3	22,000	2.40	1,310	7/8	3/8	3/4	3/8	7/8	3/8		
	E(U,C,M,H)1P43C	A80+2V110C20	15.5	12.5	35,000	25,400	8.5	34,600	3.3	22,000	2.40	1,310	7/8	3/8	7/8	3/8	7/8	3/8		
	E(U,C,M,H)1P36B	A80UHIE090B16*	14.5	12.0	35,000	25,400	8.5	34,600	3.3	22,000	2.40	1,310	7/8	3/8	3/4	3/8	7/8	3/8		
	E(U,C,M,H)1P43B	A80UHIE090B16*	14.5	12.0	35,000	25,400	8.5	34,600	3.3	22,000	2.40	1,310	7/8	3/8	7/8	3/8	7/8	3/8		
	E(U,C,M,H)1P36B	A80#2V090B16	15.0	12.0	35,000	25,400	8.5	34,600	3.3	22,000	2.40	1,310	7/8	3/8	3/4	3/8	7/8	3/8		
	E(U,C,M,H)1P36C	A80#2V090C20	15.0	12.5	35,000	25,400	8.5	34,600	3.3	22,000	2.40	1,310	7/8	3/8	3/4	3/8	7/8	3/8		
	E(U,C,M,H)1P43C	A80#2V090C20	15.0	12.5	35,000	25,400	8.5	34,600	3.3	22,000	2.40	1,310	7/8	3/8	7/8	3/8	7/8	3/8		
	E(U,C,M,H)1P36B	A95DFIE070B16S	14.0	12.5	35,000	25,400	8.5	34,600	3.3	22,000	2.40	1,310	7/8	3/8	3/4	3/8	7/8	3/8		
	E(U,C,M,H)1P43B	A95DFIE070B16S	14.0	11.5	35,000	25,400	8.5	34,600	3.3	22,000	2.40	1,310	7/8	3/8	7/8	3/8	7/8	3/8		
	E(U,C,M,H)1P36C	A95DFIE090C16S	15.0	12.0	35,000	25,400	8.5	34,600	3.3	22,000	2.40	1,310	7/8	3/8	3/4	3/8	7/8	3/8		
	E(U,C,M,H)1P43C	A95DFIE090C16S	14.5	12.0	35,000	25,400	8.5	34,600	3.3	22,000	2.40	1,310	7/8	3/8	7/8	3/8	7/8	3/8		
	E(U,C,M,H)1P36B	A95DF2V045B12S	15.0	12.5	35,000	25,400	8.5	34,600	3.3	22,000	2.40	1,310	7/8	3/8	3/4	3/8	7/8	3/8		
	E(U,C,M,H)1P43B	A95DF2V045B12S	15.0	12.0	35,000	25,400	8.5	34,600	3.3	22,000	2.40	1,310	7/8	3/8	7/8	3/8	7/8	3/8		
	E(U,C,M,H)1P36B	A95DF2V070B16S	15.0	12.0	35,000	25,400	8.5	34,600	3.3	22,000	2.40	1,310	7/8	3/8	3/4	3/8	7/8	3/8		
	E(U,C,M,H)1P43B	A95DF2V070B16S	15.0	12.0	35,000	25,400	8.5	34,600	3.3	22,000	2.40	1,310	7/8	3/8	7/8	3/8	7/8	3/8		
	E(U,C,M,H)1P36C	A95DF2V090C20S	15.0	12.5	35,000	25,400	8.5	34,600	3.3	22,000	2.40	1,310	7/8	3/8	3/4	3/8	7/8	3/8		
	E(U,C,M,H)1P43C	A95DF2V090C20S	15.0	12.5	35,000	25,400	8.5	34,600	3.3	22,000	2.40	1,310	7/8	3/8	7/8	3/8	7/8	3/8		
	E(U,C,M,H)1P36C	A95DF2V110C20S	15.0	12.5	35,000	25,400	8.5	34,600	3.3	22,000	2.40	1,310	7/8	3/8	3/4	3/8	7/8	3/8		
E(U,C,M,H)1P43C	A95DF2V110C20S	15.0	12.5	35,000	25,400	8.5	34,600	3.3	22,000	2.40	1,310	7/8	3/8	7/8	3/8	7/8	3/8			
E(U,C,M,H)1P36C	A95UHIE090C16S	15.0	12.0	35,000	25,400	8.5	34,600	3.3	22,000	2.40	1,310	7/8	3/8	3/4	3/8	7/8	3/8			
E(U,C,M,H)1P43C	A95UHIE090C16S	15.0	12.0	35,000	25,400	8.5	34,600	3.3	22,000	2.40	1,310	7/8	3/8	7/8	3/8	7/8	3/8			

**COOLING PERFORMANCE WITH AIR HANDLERS AND FURNACES**

Outdoor Model	Indoor Model		Cooling				Heating				CFM	Refrigerant Connection				Refrig. Line Size		Indoor Expansion Device		
	Evaporator Coil or Air Handler <sup>2</sup>	Furnaces	SEER	EER	ARI Rated Capacity	Rated Sensible Capacity	HSPF	47		17		Outdoor		Indoor		Suction	Liquid	Piston <sup>2</sup>	TXV	
								Btuh	COP	Btuh		COP	Suction	Liquid	Suction					Liquid
<b>4SHP16LS136P-2</b>	E(U,C,M,H)1P36B	A95UH2V045B12S	15.0	12.5	35,000	25,400	8.5	34,600	3.3	22,000	2.40	1,310	7/8	3/8	3/4	3/8	7/8	3/8	NA	H4TXV01
	E(U,C,M,H)1P43B	A95UH2V045B12S	15.0	12.0	35,000	25,400	8.5	34,600	3.3	22,000	2.40	1,310	7/8	3/8	7/8	3/8	7/8	3/8		
	E(U,C,M,H)1P36B	A95UH2V070B12S	15.0	12.5	35,000	25,400	8.5	34,600	3.3	22,000	2.40	1,310	7/8	3/8	3/4	3/8	7/8	3/8		
	E(U,C,M,H)1P43B	A95UH2V070B12S	15.0	12.0	35,000	25,400	8.5	34,600	3.3	22,000	2.40	1,310	7/8	3/8	7/8	3/8	7/8	3/8		
	E(U,C,M,H)1P36C	A95UH2V090C12S	15.0	12.5	35,000	25,400	8.5	34,600	3.3	22,000	2.40	1,310	7/8	3/8	3/4	3/8	7/8	3/8		
	E(U,C,M,H)1P43C	A95UH2V090C12S	15.0	12.5	35,000	25,400	8.5	34,600	3.3	22,000	2.40	1,310	7/8	3/8	7/8	3/8	7/8	3/8		
	E(U,C,M,H)1P36C	A95UH2V090C16S	15.0	12.5	35,000	25,400	8.5	34,600	3.3	22,000	2.40	1,310	7/8	3/8	3/4	3/8	7/8	3/8		
	E(U,C,M,H)1P43C	A95UH2V090C16S	15.0	12.5	35,000	25,400	8.5	34,600	3.3	22,000	2.40	1,310	7/8	3/8	7/8	3/8	7/8	3/8		
	E(U,C,M,H)1P36C	A95UH2V090C20S	15.0	12.5	35,000	25,400	8.5	34,600	3.3	22,000	2.40	1,310	7/8	3/8	3/4	3/8	7/8	3/8		
	E(U,C,M,H)1P43C	A95UH2V090C20S	15.5	12.5	35,000	25,400	8.5	34,600	3.3	22,000	2.40	1,310	7/8	3/8	7/8	3/8	7/8	3/8		
	E(U,C,M,H)1P36C	A95UH2V110C16S	15.0	12.5	35,000	25,400	8.5	34,600	3.3	22,000	2.40	1,310	7/8	3/8	3/4	3/8	7/8	3/8		
	E(U,C,M,H)1P43C	A95UH2V110C16S	15.5	12.5	35,000	25,400	8.5	34,600	3.3	22,000	2.40	1,310	7/8	3/8	7/8	3/8	7/8	3/8		
	E(U,C,M,H)1P36C	A96DFMV090C16 A97DSMV090C16	15.0	12.5	35,000	25,400	8.5	34,600	3.3	22,000	2.40	1,310	7/8	3/8	3/4	3/8	7/8	3/8		
	E(U,C,M,H)1P43C	A96DFMV090C16 A97DSMV090C16	15.5	12.5	35,000	25,400	8.5	34,600	3.3	22,000	2.40	1,310	7/8	3/8	7/8	3/8	7/8	3/8		
	E(U,C,M,H)1P36C	A96DFMV090C20 A97DSMV090C20	15.0	12.5	35,000	25,400	8.5	34,600	3.3	22,000	2.40	1,310	7/8	3/8	3/4	3/8	7/8	3/8		
	E(U,C,M,H)1P43C	A96DFMV090C20 A97DSMV090C20	15.5	12.5	35,000	25,400	8.5	34,600	3.3	22,000	2.40	1,310	7/8	3/8	7/8	3/8	7/8	3/8		
	E(U,C,M,H)1P36C	A96DFMV110C20 A97DSMV110C20	15.0	12.5	35,000	25,400	8.5	34,600	3.3	22,000	2.40	1,310	7/8	3/8	3/4	3/8	7/8	3/8		
	E(U,C,M,H)1P43C	A96DFMV110C20 A97DSMV110C20	15.5	12.5	35,000	25,400	8.5	34,600	3.3	22,000	2.40	1,310	7/8	3/8	7/8	3/8	7/8	3/8		
	E(U,C,M,H)1P36C	A96UHMV090C12 A97USMV090C12	15.0	12.5	35,000	25,400	8.5	34,600	3.3	22,000	2.40	1,310	7/8	3/8	3/4	3/8	7/8	3/8		
	E(U,C,M,H)1P43C	A96UHMV090C12 A97USMV090C12	15.0	12.5	35,000	25,400	8.5	34,600	3.3	22,000	2.40	1,310	7/8	3/8	7/8	3/8	7/8	3/8		
	E(U,C,M,H)1P36C	A96UHMV090C16 A97USMV090C16	15.0	12.5	35,000	25,400	8.5	34,600	3.3	22,000	2.40	1,310	7/8	3/8	3/4	3/8	7/8	3/8		
	E(U,C,M,H)1P43C	A96UHMV090C16 A97USMV090C16	15.5	12.5	35,000	25,400	8.5	34,600	3.3	22,000	2.40	1,310	7/8	3/8	7/8	3/8	7/8	3/8		
	E(U,C,M,H)1P36C	A96UHMV110C20 A97USMV110C20	15.0	12.5	35,000	25,400	8.5	34,600	3.3	22,000	2.40	1,310	7/8	3/8	3/4	3/8	7/8	3/8		
	E(U,C,M,H)1P43C	A96UHMV110C20 A97USMV110C20	15.5	12.5	35,000	25,400	8.5	34,600	3.3	22,000	2.40	1,310	7/8	3/8	7/8	3/8	7/8	3/8		
E(U,C,M,H)1P36B	LBR,LUF*****V14	14.5	12.0	35,000	25,400	8.0	34,600	3.0	22,000	2.00	1,310	7/8	3/8	3/4	3/8	7/8	3/8			
E(U,C,M,H)1P43B	LBR,LUF*****V14	14.5	12.0	35,000	25,400	8.0	34,600	3.0	22,000	2.00	1,310	7/8	3/8	7/8	3/8	7/8	3/8			
E(U,C,M,H)1P36B	LHF,LHR,LUF*****V12	14.5	12.0	35,000	25,400	8.0	34,600	3.0	22,000	2.00	1,310	7/8	3/8	3/4	3/8	7/8	3/8			
E(U,C,M,H)1P43B	LHF,LHR,LUF*****V12	14.5	12.0	35,000	25,400	8.0	34,600	3.0	22,000	2.00	1,310	7/8	3/8	7/8	3/8	7/8	3/8			
E(U,C,M,H)1P36C	LUF*****V20	15.0	12.5	35,000	25,400	8.5	34,600	3.3	22,000	2.40	1,310	7/8	3/8	3/4	3/8	7/8	3/8			
<b>4SHP16LS148P-2</b>	BCS2M48@00NA1P		16.0	12.0	46,000	33,500	8.5	45,500	3.2	29,000	2.40	1,600	7/8	3/8	7/8	3/8	7/8	3/8	NA	H4TXV02
	E(U,C,H)1P49C	EFV16CC	14.5	11.0	46,000	33,100	8.0	45,500	3.0	29,000	2.00	1,600	7/8	3/8	7/8	3/8	7/8	3/8		
	E(U,C,H)1P62C	EFV16CC	15.0	11.5	46,000	33,100	8.0	45,500	3.0	29,000	2.00	1,600	7/8	3/8	7/8	3/8	7/8	3/8		
	E(U,C,H)1P49C	A80DFIE110C20	14.0	11.5	46,000	33,500	8.5	45,500	3.3	29,000	2.40	1,600	7/8	3/8	7/8	3/8	7/8	3/8		
	E(U,C,H)1P62C	A80DFIE110C20	14.0	11.5	46,000	33,500	8.5	45,500	3.3	29,000	2.40	1,600	7/8	3/8	7/8	3/8	7/8	3/8		
	E(U,C,H)1P49C	A80+2V110C20	15.0	11.5	46,000	33,500	8.5	45,500	3.3	29,000	2.40	1,600	7/8	3/8	7/8	3/8	7/8	3/8		

**COOLING PERFORMANCE WITH AIR HANDLERS AND FURNACES**

Outdoor Model	Indoor Model		Cooling				Heating				CFM	Refrigerant Connection				Refrig. Line Size		Indoor Expansion Device		
	Evaporator Coil or Air Handler <sup>2</sup>	Furnaces	SEER	EER	ARI Rated Capacity	Rated Sensible Capacity	HSPF	47		17		Outdoor		Indoor		Suction	Liquid	Piston <sup>2</sup>	TXV	
								Btuh	COP	Btuh		COP	Suction	Liquid						
															Suction					Liquid
4SHP16LS148P-2	E(U,C,H)1P62C	A80+2V110C20	15.0	11.5	46,000	33,500	8.5	45,500	3.3	29,000	2.40	1,600	7/8	3/8	7/8	3/8	7/8	3/8	NA	H4TXV02
	E(U,C,H)1P62C	A80+2V110C20	15.0	11.5	46,000	33,500	8.5	45,500	3.3	29,000	2.40	1,600	7/8	3/8	7/8	3/8	7/8	3/8	NA	H4TXV02
	E(U,C,H)1P49C	A80UHIE090C20*	14.5	11.5	46,000	33,500	8.5	45,500	3.3	29,000	2.40	1,600	7/8	3/8	7/8	3/8	7/8	3/8	NA	H4TXV02
	E(U,C,H)1P62C	A80UHIE090C20*	14.5	11.5	46,000	33,500	8.5	45,500	3.3	29,000	2.40	1,600	7/8	3/8	7/8	3/8	7/8	3/8	NA	H4TXV02
	E(U,C,H)1P49C	A80UHIE110C20*	14.5	11.5	46,000	33,500	8.5	45,500	3.3	29,000	2.40	1,600	7/8	3/8	7/8	3/8	7/8	3/8	NA	H4TXV02
	E(U,C,H)1P62C	A80UHIE110C20*	14.5	11.5	46,000	33,500	8.5	45,500	3.3	29,000	2.40	1,600	7/8	3/8	7/8	3/8	7/8	3/8	NA	H4TXV02
	E(U,C,H)1P49C	A80#2V090C20	15.0	11.5	46,000	33,500	8.5	45,500	3.3	29,000	2.40	1,600	7/8	3/8	7/8	3/8	7/8	3/8	NA	H4TXV02
	E(U,C,H)1P62C	A80#2V090C20	15.0	11.5	46,000	33,500	8.5	45,500	3.3	29,000	2.40	1,600	7/8	3/8	7/8	3/8	7/8	3/8	NA	H4TXV02
	E(U,C,H)1P49C	A80#2V110C20	15.0	11.5	46,000	33,500	8.5	45,500	3.3	29,000	2.40	1,600	7/8	3/8	7/8	3/8	7/8	3/8	NA	H4TXV02
	E(U,C,H)1P62C	A80#2V110C20	15.0	11.5	46,000	33,500	8.5	45,500	3.3	29,000	2.40	1,600	7/8	3/8	7/8	3/8	7/8	3/8	NA	H4TXV02
	E(U,C,H)1P49C	A95DFIE110C20S	13.5	11.5	46,000	33,500	8.5	45,500	3.3	29,000	2.40	1,600	7/8	3/8	7/8	3/8	7/8	3/8	NA	H4TXV02
	E(U,C,H)1P62C	A95DFIE110C20S	14.0	11.5	46,000	33,500	8.5	45,500	3.3	29,000	2.40	1,600	7/8	3/8	7/8	3/8	7/8	3/8	NA	H4TXV02
	E(U,C,H)1P49C	A95DF2V090C20S	14.5	11.0	46,000	33,500	8.5	45,500	3.3	29,000	2.40	1,600	7/8	3/8	7/8	3/8	7/8	3/8	NA	H4TXV02
	E(U,C,H)1P62C	A95DF2V090C20S	14.5	11.0	46,000	33,500	8.5	45,500	3.3	29,000	2.40	1,600	7/8	3/8	7/8	3/8	7/8	3/8	NA	H4TXV02
	E(U,C,H)1P49C	A95DF2V110C20S	15.0	11.0	46,000	33,500	8.5	45,500	3.3	29,000	2.40	1,600	7/8	3/8	7/8	3/8	7/8	3/8	NA	H4TXV02
	E(U,C,H)1P62C	A95DF2V110C20S	15.0	11.0	46,000	33,500	8.5	45,500	3.3	29,000	2.40	1,600	7/8	3/8	7/8	3/8	7/8	3/8	NA	H4TXV02
	E(U,C,H)1P49C	A95UHIE110C20S	13.5	11.5	46,000	33,500	8.5	45,500	3.3	29,000	2.40	1,600	7/8	3/8	7/8	3/8	7/8	3/8	NA	H4TXV02
	E(U,C,H)1P62C	A95UHIE110C20S	14.0	11.5	46,000	33,500	8.5	45,500	3.3	29,000	2.40	1,600	7/8	3/8	7/8	3/8	7/8	3/8	NA	H4TXV02
	E(U,C,H)1P49C	A95UH2V090C16S	14.5	11.0	46,000	33,500	8.5	45,500	3.3	29,000	2.40	1,600	7/8	3/8	7/8	3/8	7/8	3/8	NA	H4TXV02
	E(U,C,H)1P62C	A95UH2V090C16S	15.0	11.0	46,000	33,500	8.5	45,500	3.3	29,000	2.40	1,600	7/8	3/8	7/8	3/8	7/8	3/8	NA	H4TXV02
	E(U,C,H)1P49C	A95UH2V090C20S	15.0	11.5	46,000	33,500	8.5	45,500	3.3	29,000	2.40	1,600	7/8	3/8	7/8	3/8	7/8	3/8	NA	H4TXV02
	E(U,C,H)1P62C	A95UH2V090C20S	15.0	11.5	46,000	33,500	8.5	45,500	3.3	29,000	2.40	1,600	7/8	3/8	7/8	3/8	7/8	3/8	NA	H4TXV02
	E(U,C,H)1P49C	A95UH2V110C16S	15.0	11.5	46,000	33,500	8.5	45,500	3.3	29,000	2.40	1,600	7/8	3/8	7/8	3/8	7/8	3/8	NA	H4TXV02
	E(U,C,H)1P62C	A95UH2V110C16S	15.0	11.5	46,000	33,500	8.5	45,500	3.3	29,000	2.40	1,600	7/8	3/8	7/8	3/8	7/8	3/8	NA	H4TXV02
	E(U,C,H)1P49C	A95UH2V110C20S	15.0	11.5	46,000	33,500	8.5	45,500	3.3	29,000	2.40	1,600	7/8	3/8	7/8	3/8	7/8	3/8	NA	H4TXV02
	E(U,C,H)1P62C	A95UH2V110C20S	15.0	11.5	46,000	33,500	8.5	45,500	3.3	29,000	2.40	1,600	7/8	3/8	7/8	3/8	7/8	3/8	NA	H4TXV02
	E(U,C,H)1P49C	A96DFMV090C16 A97DSMV090C16	15.0	11.0	46,000	33,500	8.5	45,500	3.3	29,000	2.40	1,600	7/8	3/8	7/8	3/8	7/8	3/8	NA	H4TXV02
	E(U,C,H)1P62C	A96DFMV090C16 A97DSMV090C16	15.0	11.5	46,000	33,500	8.5	45,500	3.3	29,000	2.40	1,600	7/8	3/8	7/8	3/8	7/8	3/8	NA	H4TXV02
	E(U,C,H)1P49C	A96DFMV090C20 A97DSMV090C20	14.5	11.0	46,000	33,500	8.5	45,500	3.3	29,000	2.40	1,600	7/8	3/8	7/8	3/8	7/8	3/8	NA	H4TXV02
	E(U,C,H)1P62C	A96DFMV090C20 A97DFMV090C20	14.5	11.0	46,000	33,500	8.5	45,500	3.3	29,000	2.40	1,600	7/8	3/8	7/8	3/8	7/8	3/8	NA	H4TXV02
E(U,C,H)1P49C	A96DFMV110C20 A97DSMV110C20	15.0	11.0	46,000	33,500	8.5	45,500	3.3	29,000	2.40	1,600	7/8	3/8	7/8	3/8	7/8	3/8	NA	H4TXV02	
E(U,C,H)1P62C	A96DFMV110C20 A97DSMV110C20	14.5	11.0	46,000	33,500	8.5	45,500	3.3	29,000	2.40	1,600	7/8	3/8	7/8	3/8	7/8	3/8	NA	H4TXV02	
E(U,C,H)1P49C	A96UHMV090C16 A97USMV090C16	14.5	11.0	46,000	33,500	8.5	45,500	3.3	29,000	2.40	1,600	7/8	3/8	7/8	3/8	7/8	3/8	NA	H4TXV02	
E(U,C,H)1P62C	A96UHMV090C16 A97USMV090C16	14.5	11.0	46,000	33,500	8.5	45,500	3.3	29,000	2.40	1,600	7/8	3/8	7/8	3/8	7/8	3/8	NA	H4TXV02	
E(U,C,H)1P49C	A96UHMV090C20 A97USMV090C20	14.5	11.5	46,000	33,500	8.5	45,500	3.3	29,000	2.40	1,600	7/8	3/8	7/8	3/8	7/8	3/8	NA	H4TXV02	

**COOLING PERFORMANCE WITH AIR HANDLERS AND FURNACES**

Outdoor Model	Indoor Model		Cooling				Heating				CFM	Refrigerant Connection				Refrig. Line Size		Indoor Expansion Device		
	Evaporator Coil or Air Handler <sup>2</sup>	Furnaces	SEER	EER	ARI Rated Capacity	Rated Sensible Capacity	HSPF	47		17		Outdoor		Indoor		Suction	Liquid	Piston <sup>2</sup>	TXV	
								Btuh	COP	Btuh		COP	Suction	Liquid						
															Suction					Liquid
4SHP16LS148P-2	E(U,C,H)1P62C	A96UHMV090C20 A97USMV090C20	14.5	11.5	46,000	33,500	8.5	45,500	3.3	29,000	2.40	1,600	7/8	3/8	7/8	3/8	7/8	3/8	NA	H4TXV02
	E(U,C,H)1P49C	A96UHMV110C20 A97USMV110C20	15.0	11.5	46,000	33,500	8.5	45,500	3.3	29,000	2.40	1,600	7/8	3/8	7/8	3/8	7/8	3/8		
	E(U,C,H)1P62C	A96UHMV110C20 A97USMV110C20	15.0	11.5	46,000	33,500	8.5	45,500	3.3	29,000	2.40	1,600	7/8	3/8	7/8	3/8	7/8	3/8		
	E(U,C,H)1P49C	LBR,LUF*****V14	14.5	11.5	46,000	33,100	8.0	45,500	3.0	29,000	2.00	1,600	7/8	3/8	7/8	3/8	7/8	3/8		
	E(U,C,H)1P62C	LBR,LUF*****V14	14.0	11.5	46,000	33,100	8.0	45,500	3.0	29,000	2.00	1,600	7/8	3/8	7/8	3/8	7/8	3/8		
	E(U,C,H)1P49C	LUF*****V20	14.0	11.5	46,000	33,100	8.0	45,500	3.0	29,000	2.00	1,600	7/8	3/8	7/8	3/8	7/8	3/8		
	E(U,C,H)1P62C	LUF*****V20	14.0	11.5	46,000	33,100	8.0	45,500	3.0	29,000	2.00	1,600	7/8	3/8	7/8	3/8	7/8	3/8		
4SHP16LS160P-2	BCS2M60@00NA1P		15.0	11.5	58,000	43,000	8.5	58,000	3.3	35,000	2.40	1,920	7/8	3/8	7/8	3/8	11/8	3/8	NA	H4TXV03
	E(U,C,H)1P62D	EFV20DC	14.5	11.0	58,000	43,000	8.0	58,000	3.3	35,000	2.40	1,920	7/8	3/8	7/8	3/8	11/8	3/8		
	E(U,C,H)1P62C	A80+2V110C20	15.0	11.4	58,000	43,000	8.5	58,000	3.3	35,000	2.40	1,920	7/8	3/8	7/8	3/8	11/8	3/8		
	E(U,C,H)1P62C	A80UH1E090C20*	14.0	11.0	58,000	43,000	8.5	58,000	3.3	35,000	2.40	1,920	7/8	3/8	7/8	3/8	11/8	3/8		
	E(U,C,H)1P62C	A80UH1E110C20*	14.0	11.0	58,000	43,000	8.5	58,000	3.3	35,000	2.40	1,920	7/8	3/8	7/8	3/8	11/8	3/8		
	E(U,C,H)1P62C	A80#2V090C20	14.5	11.4	58,000	43,000	8.5	58,000	3.3	35,000	2.40	1,920	7/8	3/8	7/8	3/8	11/8	3/8		
	E(U,C,H)1P62C	A80#2V110C20	14.0	11.0	58,000	43,000	8.5	58,000	3.3	35,000	2.40	1,920	7/8	3/8	7/8	3/8	11/8	3/8		
	E(U,C,H)1P62D	A80#2V135D20	14.5	11.0	58,000	43,000	8.5	58,000	3.3	35,000	2.40	1,920	7/8	3/8	7/8	3/8	11/8	3/8		
	E(U,C,H)1P62C	A95DF1E110C20S	14.0	11.0	58,000	43,000	8.5	58,000	3.3	35,000	2.40	1,920	7/8	3/8	7/8	3/8	11/8	3/8		
	E(U,C,H)1P62C	A95DF2V090C20S	14.5	11.0	58,000	43,000	8.5	58,000	3.3	35,000	2.40	1,920	7/8	3/8	7/8	3/8	11/8	3/8		
	E(U,C,H)1P62C	A95DF2V110C20S	14.5	11.0	58,000	43,000	8.5	58,000	3.3	35,000	2.40	1,920	7/8	3/8	7/8	3/8	11/8	3/8		
	E(U,C,H)1P62C	A95UH1E110C20S	14.0	11.0	58,000	43,000	8.5	58,000	3.3	35,000	2.40	1,920	7/8	3/8	7/8	3/8	11/8	3/8		
	E(U,C,H)1P62D	A95UH1E135D20S	13.5	10.5	58,000	43,000	8.5	58,000	3.3	35,000	2.40	1,920	7/8	3/8	7/8	3/8	11/8	3/8		
	E(U,C,H)1P62C	A95UH2V090C20S	14.5	11.0	58,000	43,000	8.5	58,000	3.3	35,000	2.40	1,920	7/8	3/8	7/8	3/8	11/8	3/8		
	E(U,C,H)1P62C	A95UH2V110C20S	14.5	11.0	58,000	43,000	8.5	58,000	3.3	35,000	2.40	1,920	7/8	3/8	7/8	3/8	11/8	3/8		
	E(U,C,H)1P62D	A95UH2V135D20S	14.5	11.0	58,000	43,000	8.5	58,000	3.3	35,000	2.40	1,920	7/8	3/8	7/8	3/8	11/8	3/8		
	E(U,C,H)1P62C	A96DFMV090C20 A97DSMV090C20	14.5	11.0	58,000	43,000	8.5	58,000	3.3	35,000	2.40	1,920	7/8	3/8	7/8	3/8	11/8	3/8		
	E(U,C,H)1P62C	A96DFMV110C20 A97DSMV110C20	14.5	11.0	58,000	43,000	8.5	58,000	3.3	35,000	2.40	1,920	7/8	3/8	7/8	3/8	11/8	3/8		
	E(U,C,H)1P62C	A96UHMV090C20 A97USMV090C20	14.5	11.0	58,000	43,000	8.5	58,000	3.3	35,000	2.40	1,920	7/8	3/8	7/8	3/8	11/8	3/8		
	E(U,C,H)1P62C	A96UHMV110C20 A97USMV110C20	15.0	11.0	58,000	43,000	8.5	58,000	3.3	35,000	2.40	1,920	7/8	3/8	7/8	3/8	11/8	3/8		
E(U,C,H)1P62D	A96UHMV135D20 A97USMV135D20	14.5	11.0	58,000	43,000	8.5	58,000	3.3	35,000	2.40	1,920	7/8	3/8	7/8	3/8	11/8	3/8			
E(U,C,H)1P62C	LUF*****V20	14.5	11.5	58,000	43,000	8.0	58,000	3.0	35,000	2.00	1,920	7/8	3/8	7/8	3/8	11/8	3/8			

**COOLING PERFORMANCE EXTENDED RATINGS**

Outdoor Model	Indoor Model	Indoor Temp DB/WB °F	Outdoor Temp - DB°F														
			65°			82°			95°			105°			115°		
	Piston or Field Installed TXV		Btuh	S/T	kW	Btuh	S/T	kW	Btuh	S/T	kW	Btuh	S/T	kW	Btuh	S/T	kW
4SHPI6LS724P-2	BCS2M24V+TXV BCS2M24S+TXV	85/75	32,300	0.59	1.54	29,523	0.61	1.80	27,400	0.63	1.99	24,800	0.69	2.25	22,200	0.74	2.51
		80/67	29,400	0.65	1.51	26,793	0.70	1.78	24,800	0.73	1.99	22,950	0.74	2.20	21,100	0.75	2.41
		75/63	26,700	0.69	1.48	24,490	0.71	1.74	22,800	0.73	1.93	21,550	0.76	2.16	20,300	0.78	2.38
		75/57	23,100	0.73	1.45	21,400	0.74	1.71	20,100	0.74	1.90	19,250	0.77	2.00	18,400	0.79	2.10
4SHPI6LS736P-2	BCS2M36V+TXV BCS2M36S+TXV	85/75	45,000	0.60	2.40	42,223	0.66	2.73	40,100	0.71	2.99	31,750	0.80	3.30	23,400	0.89	3.60
		80/67	42,100	0.61	2.38	39,550	0.68	2.70	37,600	0.73	2.94	30,050	0.82	2.77	22,500	0.91	2.60
		75/63	39,300	0.63	2.35	37,033	0.69	2.20	35,300	0.73	2.08	28,550	0.82	2.33	21,800	0.91	2.58
		75/57	37,200	0.66	2.31	35,613	0.72	2.12	34,400	0.76	1.98	27,250	0.83	2.04	20,100	0.90	2.10
4SHPI6LS748P-2	BCS2M48V+TXV BCS2M48S+TXV	85/75	52,300	0.62	2.96	51,053	0.64	3.49	50,100	0.66	3.89	47,600	0.74	4.27	45,100	0.82	4.65
		80/67	50,600	0.68	2.12	49,127	0.70	3.11	48,000	0.72	3.87	45,300	0.77	4.26	42,600	0.81	4.65
		75/63	48,300	0.72	2.87	44,730	0.74	3.35	42,000	0.75	3.72	39,500	0.77	4.18	37,000	0.79	4.64
		75/57	46,400	0.73	2.86	43,510	0.75	3.34	41,300	0.76	3.71	38,500	0.77	4.11	35,700	0.78	4.51
4SHPI6LS760P-2	BCS2M60V+TXV BCS2M60S+TXV	85/75	74,900	0.62	3.72	69,290	0.65	4.49	65,000	0.68	5.07	61,400	0.68	5.71	57,800	0.68	6.34
		80/67	69,700	0.69	3.65	64,770	0.71	4.46	61,000	0.73	5.08	55,800	0.77	5.70	50,600	0.81	6.32
		75/63	65,100	0.73	3.63	60,170	0.75	4.37	56,400	0.76	4.93	52,050	0.80	5.57	47,700	0.83	6.20
		75/57	61,400	0.75	3.58	57,207	0.76	4.28	54,000	0.77	4.81	49,550	0.81	5.48	45,100	0.85	6.14

**HEATING PERFORMANCE EXTENDED RATINGS**

Outdoor Model	Indoor Model	Indoor Temp	Outdoor Temp - DB/WB °F									
			0/0		17/15		35/33		47/43		62/56	
	Piston or Field Installed TXV		Btuh	kW	Btuh	kW	Btuh	kW	Btuh	kW	Btuh	kW
4SHP16LS124P-2	BCS2M24V+TXV BCS2M24S+TXV	70	12,361	1.64	15,100	1.83	18,000	2.03	24,500	2.17	29,200	2.34
4SHP16LS136P-2	BCS2M36V+TXV BCS2M36S+TXV	70	15,811	2.04	22,800	2.49	30,200	2.97	40,600	3.55	49,500	4.08
4SHP16LS148P-2	BCS2M48V+TXV BCS2M48S+TXV	70	28,561	3.32	31,300	3.49	34,200	3.67	46,900	3.59	54,700	3.64
4SHP16LS160P-2	BCS2M60V+TXV BCS2M60S+TXV	70	36,783	4.04	39,900	4.17	43,200	4.31	60,300	4.73	70,500	5.01

**ACCESSORIES**

DESCRIPTION	WHERE USED	KIT CATALOG NO.
Hard Start Kit	24 & 36	10J42
	48 & 60	81J69
Compressor Low Ambient Kit	All Models	45F08
Freezestat	All Models	93G35
Outdoor Thermostat	All Models	ASTA503
Fossil Fuel Kit	All Models	AFOSL500
Low Pressure Switch	Factory installed; see spare parts list	
High Pressure Switch	Factory installed; see spare parts list	
Sound Blanket	Factory installed; see spare parts list	
Crankcase Heater	Factory installed; see spare parts list	
Relay Kit- Constant Torque	All Constant Torque Furnaces	85W66



1-800-448-5872

All specifications and illustrations subject to change without notice and without incurring obligations.